



FD50 Installation and Maintenance

MASTER PNEUMATIC-DETROIT, INC.

6701 - 18 Mile Rd | Sterling Heights, MI 48314 | Phone: (586) 254-1000 | Fax: (586) 254-6055 | Email: mp@masterpneumatic.com

JAA 09-19-05
REV MJF 06-12-13
ECN 4876

THANK YOU!

You have just purchased a quality Filter from Master Pneumatic.

With care in its installation and maintenance, you can expect it to have a long and economical service life. Before you go any further, please take a few minutes to look over this information, then save it for future reference and for the useful service information it contains.



Installation & Operation Procedures

INSTALLATION:

1. Depressurize and lockout air pressure.
2. Upstream pipes must be free of excessive dirt and liquids.
3. Install the Filter in airline as near as possible to the device it is to serve.
4. Install the Filter so air flows in same direction as arrow on head.
5. Filter should be installed before any Regulator, Lubricators or Valves in airline.

OPERATION:

1. Manual drains must be periodically drained of accumulated liquids.
For Plastic Bowls with Manual or Automatic Internal Drain, manually drain by pushing up on Drain Knob (#6).
For Metal Bowls with Manual or Automatic Internal Drain, manually drain by turning Drain Knob (#6) counter-clockwise.

TO CLEAN OR REPAIR:

1. Depressurize and lockout air pressure.
2. Remove Bowl Assembly (#3 or #7 or #8 or N.S.) by turning counter-clockwise.
3. Remove Filter Element (#2) by turning Stem (#4) counter-clockwise.
4. Do not clean white polyethylene elements, they must be replaced
5. Sintered Bronze elements may be cleaned by soaking several hours in a suitable solvent, then blowing them out with compressed air, in reverse direction to normal air flow.
6. To service automatic internal drain: Remove Bowl Assembly (#3 or #8) by turning counter-clockwise, then remove Piston Drain top (#5).
7. Clean Bowl Assembly (#3 or #8) and Piston Drain top (#5) with soap and water, then reassemble.
8. If the Filter cannot be repaired by cleaning with soap and water, the parts should be replaced.
9. Plastic bowls may be cleaned with soap and water. Replace plastic bowls with metal if any signs of crazing or cracking are observed.

Replacement Parts and Mounting Accessories

PART NUMBER	DESCRIPTION
A10FD-130	Automatic Internal Drain Bowl Kit, PLASTIC (Bowl, Knob, Drain Housing, Drain Plug, Piston Drain Top, Seal, and O-rings)
A10F-130	Manual Drain Bowl Kit, PLASTIC (Bowl, Knob, Drain Plug, O-rings)
ABFD130-22	Automatic Internal Drain Bowl Kit, METAL (Bowl, Auto Drain Stem, Knob, Drain Housing, Piston, Top, Seal, and O-rings)
ABF130-22	Manual Drain Bowl Kit, METAL (Bowl, Drain Stem, Knob, and O-rings)
KA130-27PE5	Standard Filter Element Kit, 5 um polyethylene
KA130-27E5	Optional Filter Element Kit, 5 um sintered bronze
KA130-27E4	Optional Filter Element Kit, 20 um sintered bronze
KA130-27E3	Optional Filter Element Kit, 40 um sintered bronze
K50-01	Top Mounting Bracket for 'T' suffix models (Bracket, Screws)



FD50 Installation and Maintenance

MASTER PNEUMATIC-DETROIT, INC.

6701 - 18 Mile Rd | Sterling Heights, MI 48314 | Phone: (586) 254-1000 | Fax: (586) 254-6055 | Email: mp@masterpneumatic.com

JAA 09-19-05
REV MJF 06-12-13
ECN 4876

Parts List

KEY	DESCRIPTION
1	Head
2	Filter Element
3	AID Bowl Assembly, Plastic
4	Stem
5	Piston Drain Top
6	Drain Knob
7	Manual Bowl Assembly, Plastic
8	AID Bowl Assembly, Metal
Not Shown	Manual Bowl Assembly, Metal

Section View

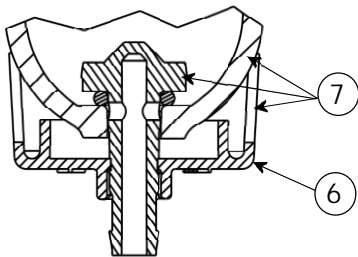
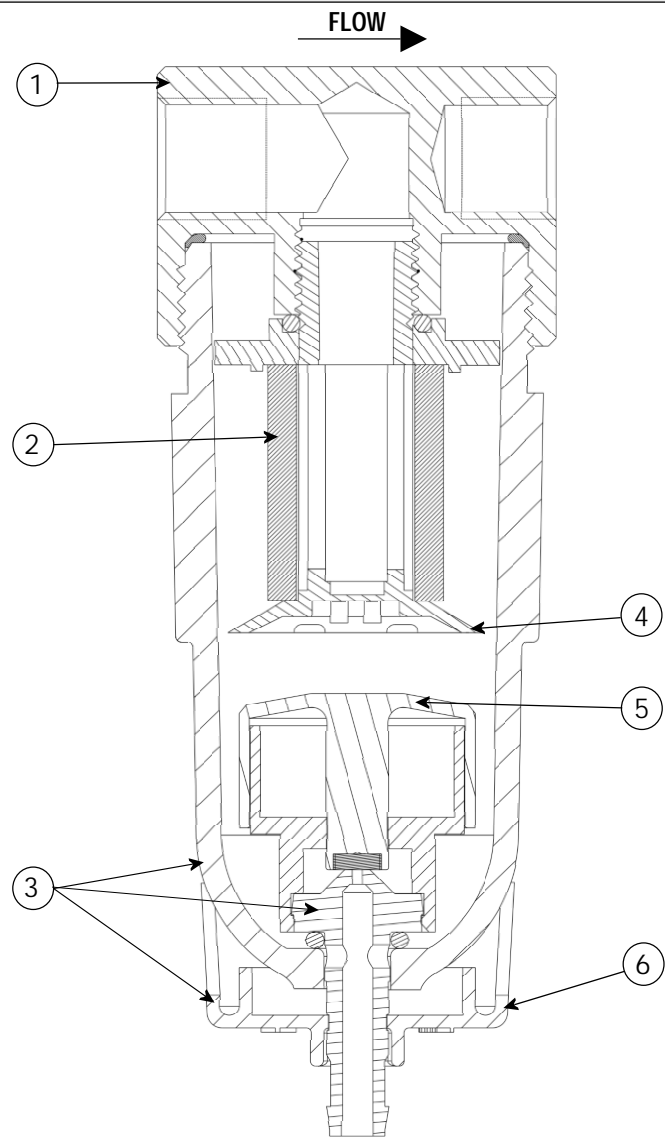

SECTION VIEW
(Plastic Bowl Manual Drain)

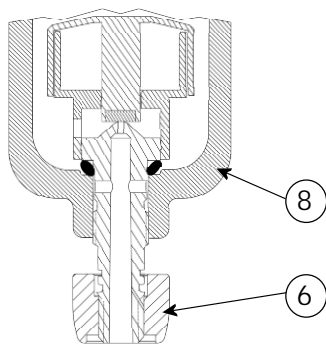

SECTION VIEW
(Metal Bowl Auto Drain)

FD50 SECTION VIEW
(Plastic Bowl Automatic Internal Drain)